

Side awning markilux® - 790



Installation notes



These installation instructions are intended for trained fitters and electricians. They specify how this awning is to be installed and first operated.

Read them carefully before installing the awning as well as our general **safety instructions**.

Check the goods supplied for completeness and shipping damage before beginning installation.

The sequence of installation and adjustment specified herein is always to be adhered to.

The side awning is shipped in the following parts.

- Completely assembled cassette in protective foil
- 2 holders for cassette wall mounting
- Depending on order: 1 retaining post with base plate, 1 retaining post with ground sleeve or 1 wall holder

1. Fastening means

Overview of dimensions

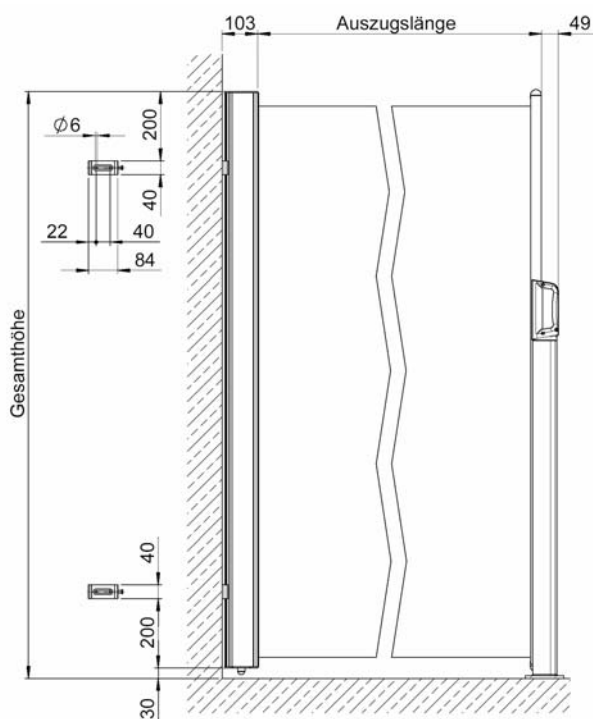

Tension sectioning fastening means

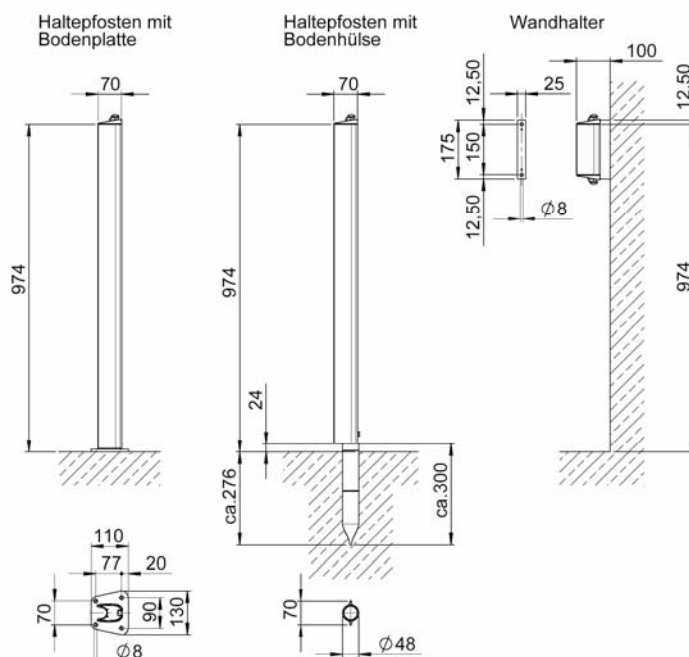

2. Recommendations and instructions on fastening holders in place

This **side awning is supplied without** assembly screws, as differing wall materials etc. require differing types of fastening.

Fastening means must be such as safely distribute the forces exerted to the object/s used to hold the awning. Mathematical proof of the tensile forces exerted on the fastening screws on the **basis of 70 N per m² pf awning fabric** is required. .

The fastening means used depends on the material it is secured to (steel beams, wood, etc.).

Maximum screw sizes for wall holder fastening:

Cheese-head screws	M6x...
Cheese-head sheet metal screws	6.3x...
Tensioning plate screws	6.0x
Wood screws	6.0x



Caution

Maximum screw head height is 5.5 mm.



3. Installing / hanging up the awning

- 3.1 Remove the protective covering and check all parts are present.
- 3.2 Mark holder site where it is to be attached with drill holes and then drill. Both holders are to be installed with a 20 cm gap to the outer edges of the cassette awning.
Additional brackets may be used.
- 3.3 Fasten the holders vertically above one another. They must be mutually aligned. (plumb line).
- 3.4 Hang the cassette in the holders, position it and tighten the SW10 securing screws.
- 3.5 Mark the position of the tension sectioning fastening means depending on awning extension length and fasten them in place.

Retaining post with base plate is to be screwed in horizontally sited on a strong base.

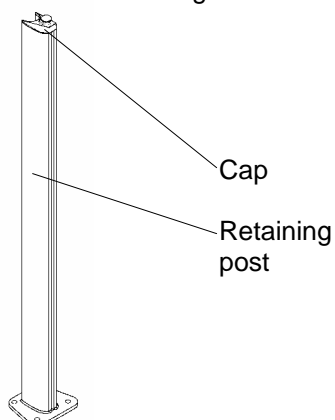

Retaining post with ground sleeve: anchor the sleeve plumb vertically in concrete, push the sectioning into the sleeve and then slide the retaining post on. Clamp the post in place with the hexagonal SW13 screw.

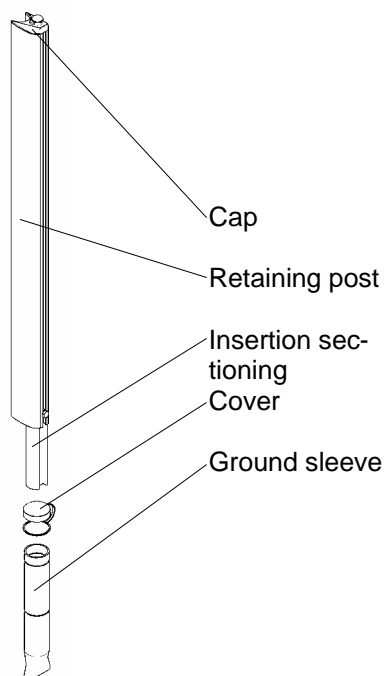

Wall holder: screw the wall plate approximately 985 mm high on the wall and mount the wall holder using the cylindrical SW4 screws.

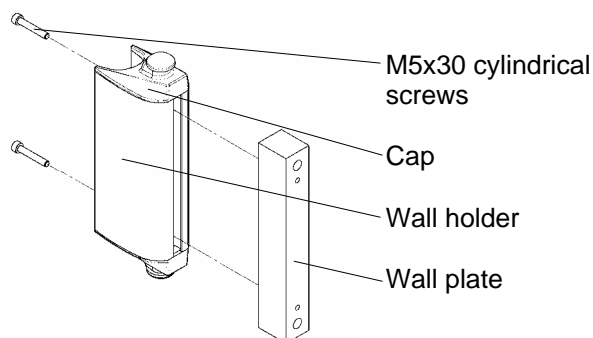

3.6 The handle position can be adjusted with the clamping screw on the tensioning arm.

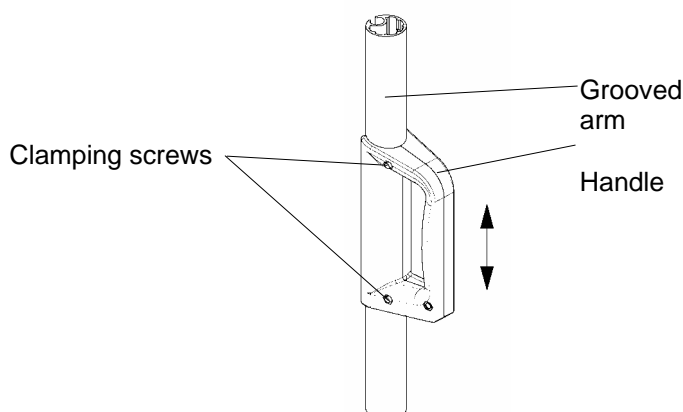

3.7 Set its height so that the awning is tensioned dead straight.

Caution. The clamping screws must be retightened after adjusting the handle height.

3. Safety note

Caution. Awning under tension. Keep a good hold of the handle when extending.

4. Important

Hand over the attached Operating Instructions to the awning user and advise him or her comprehensively on awning safety and use.